

LAM LAMP

SUSPENSIÓN, SOBREMESA Y APLIQUE CEILING, TABLE AND WALL LAMP

by Martín Azúa

REF. 4443

REF. 6993

REF. 1693

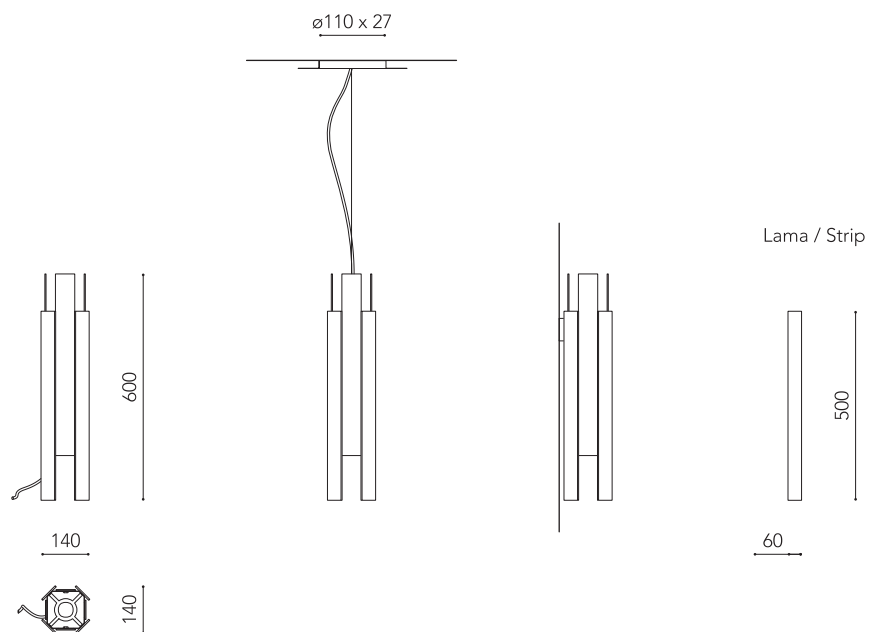

Cuerpo metálico de hierro pintado.
Lamas de madera natural imantadas.

Frame painted metal.
Natural wooden strips with magnetic connection points.



Bombilla recomendada, E27 9W LED no dimmable 3000k (800lm) incluida.

Recommended bulb, E27 9W LED no dimmable 3000k (800lm) included.

